

**2 TYPICAL EAVE & ROOF / WALL CONNECTION DETAIL**  
3/4" = 1'-0"

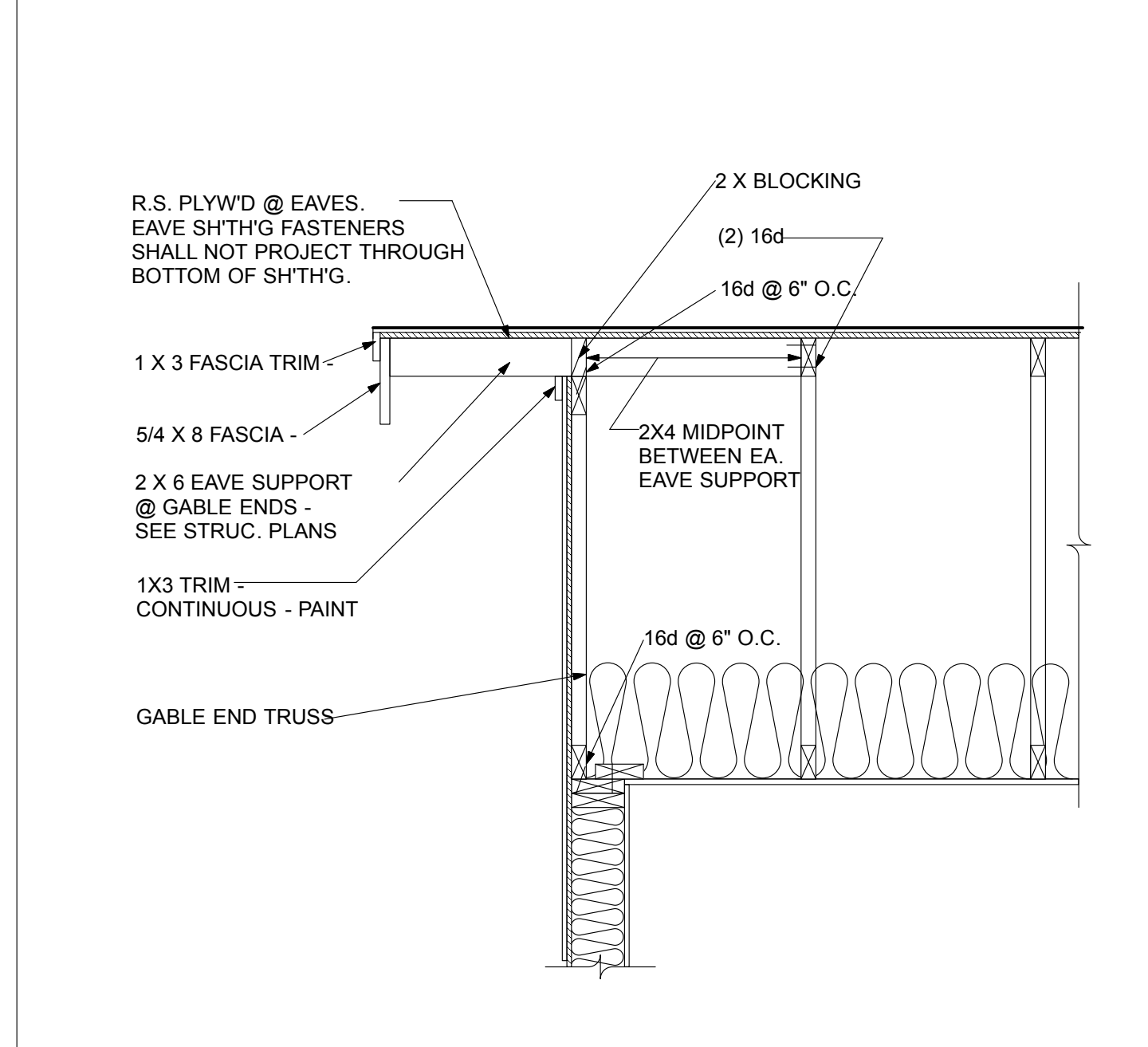

**3 TYPICAL EAVE & ROOF / WALL CONNECTION DETAIL**  
3/4" = 1'-0"

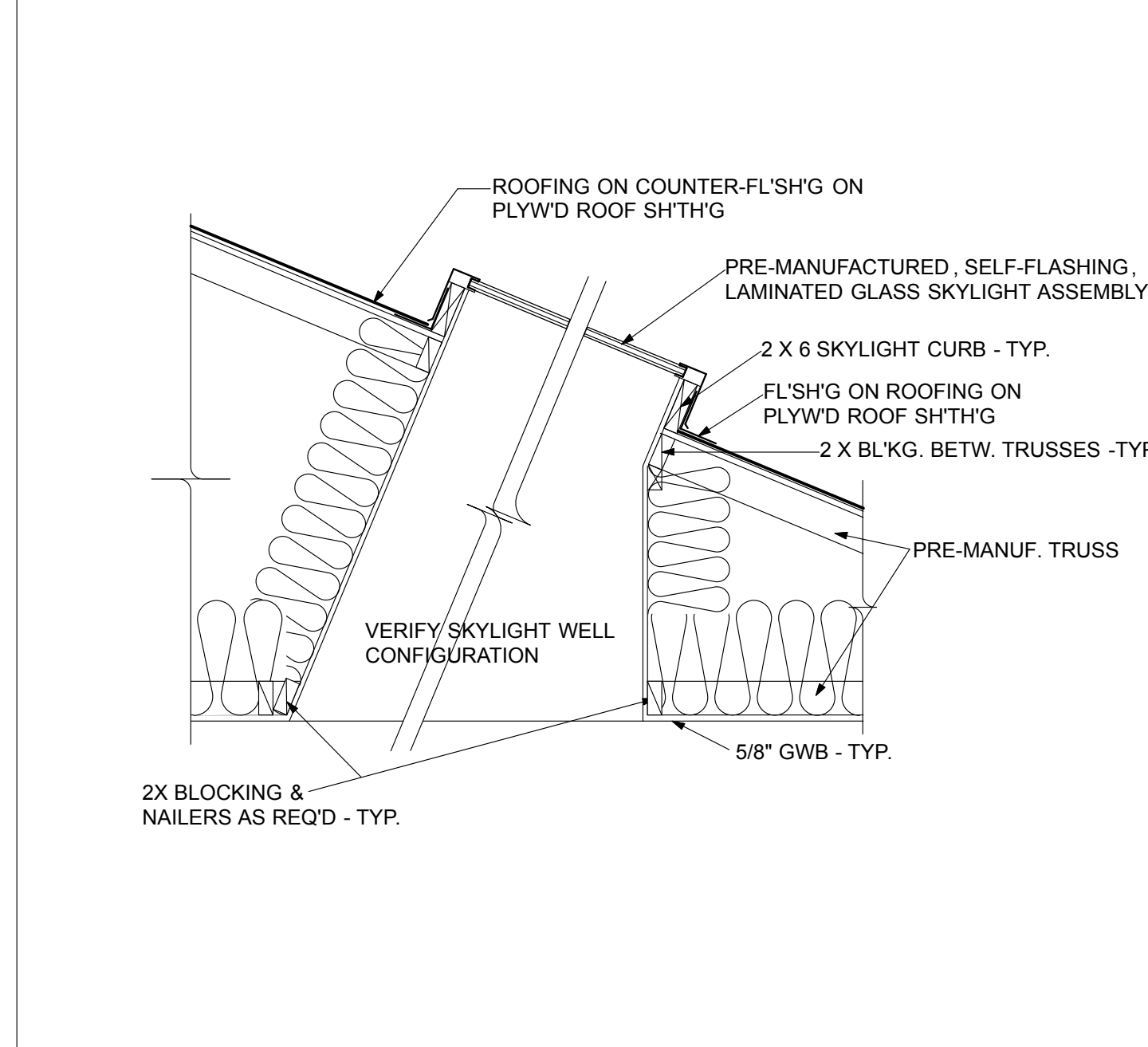

**4 SKYLIGHT DETAIL**  
3/4" = 1'-0"

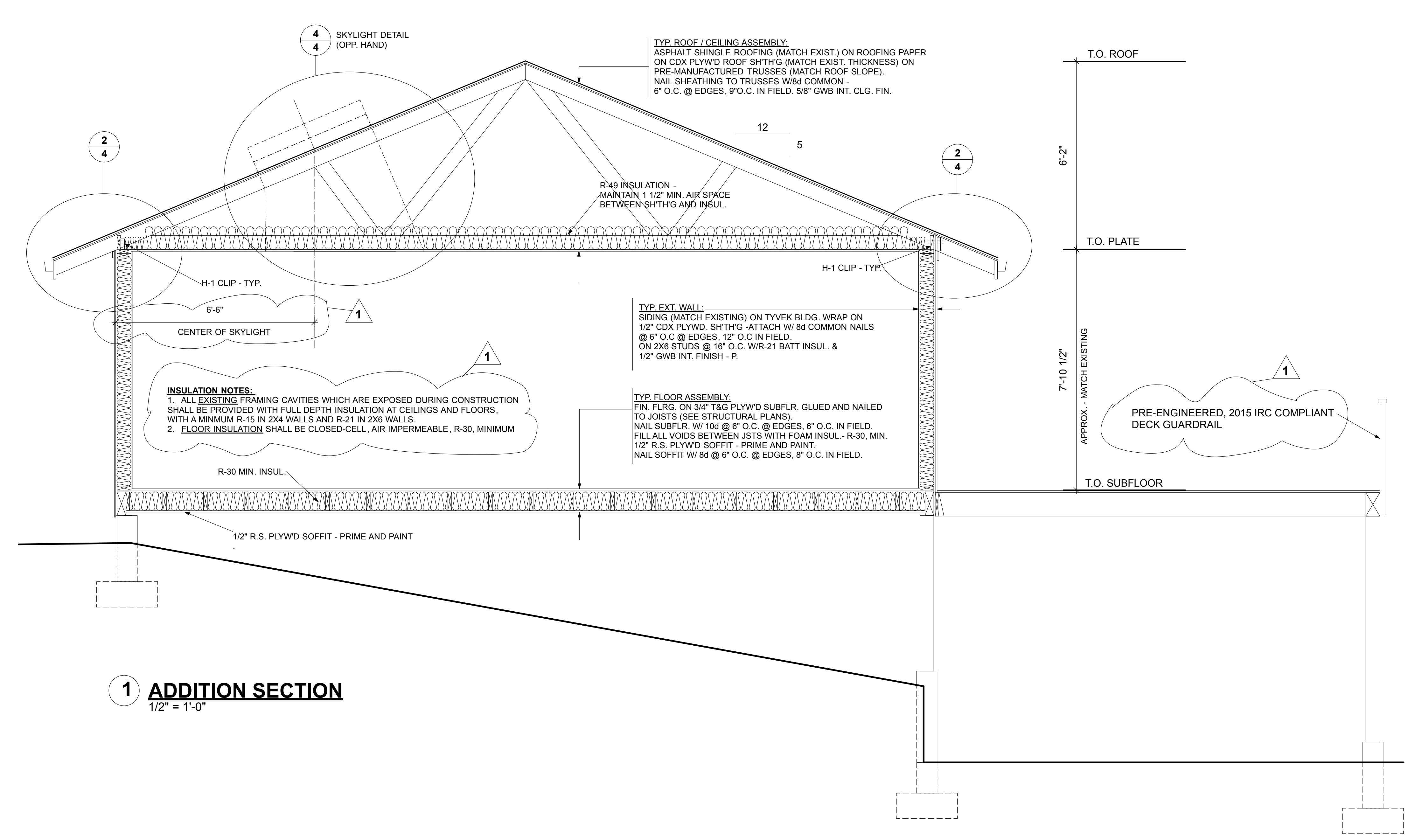

**1 ADDITION SECTION**  
1/2" = 1'-0"

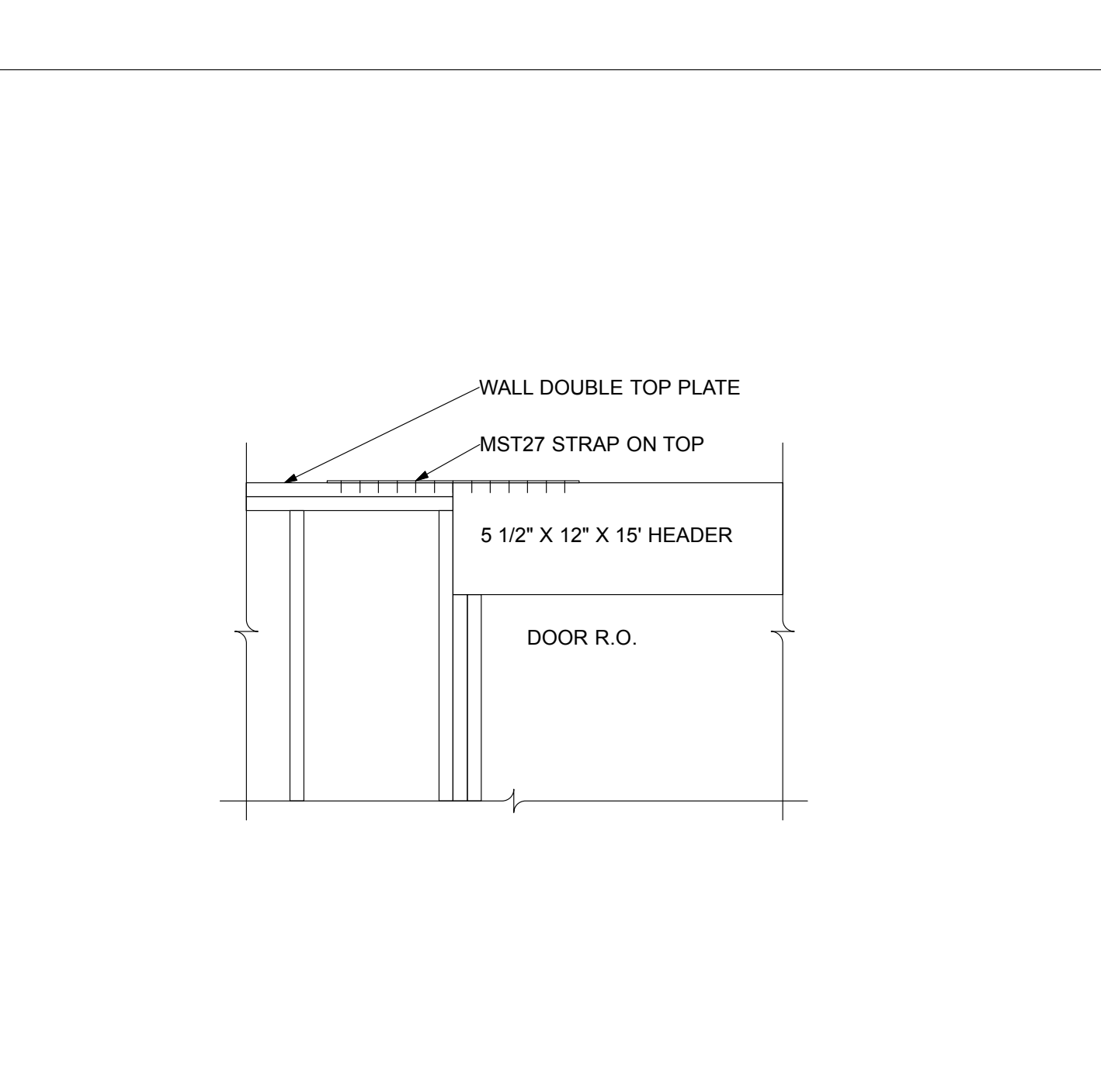

**5 HEADER DETAIL**  
3/4" = 1'-0"

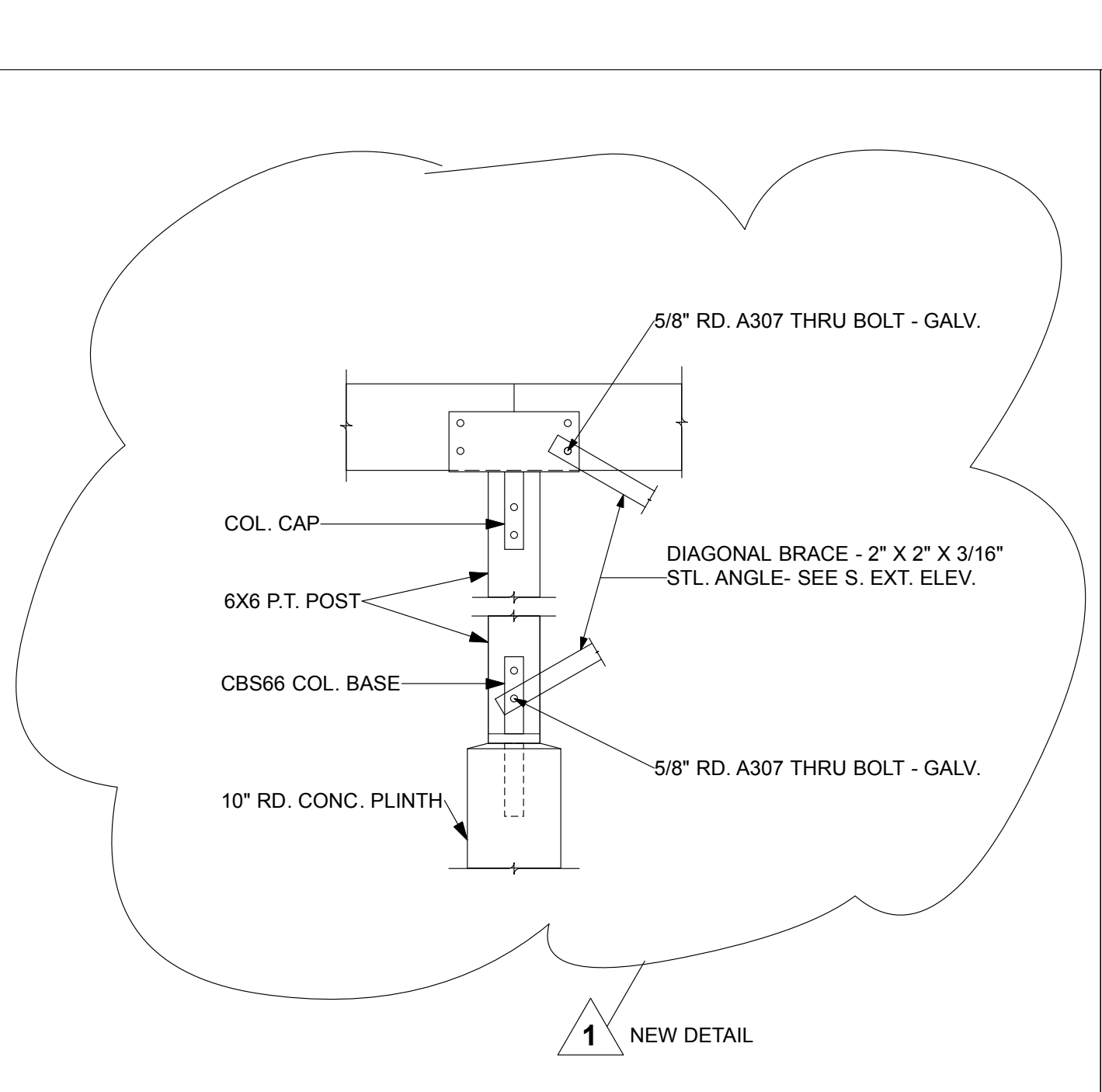

**6 BRACE DETAIL**  
3/4" = 1'-0"

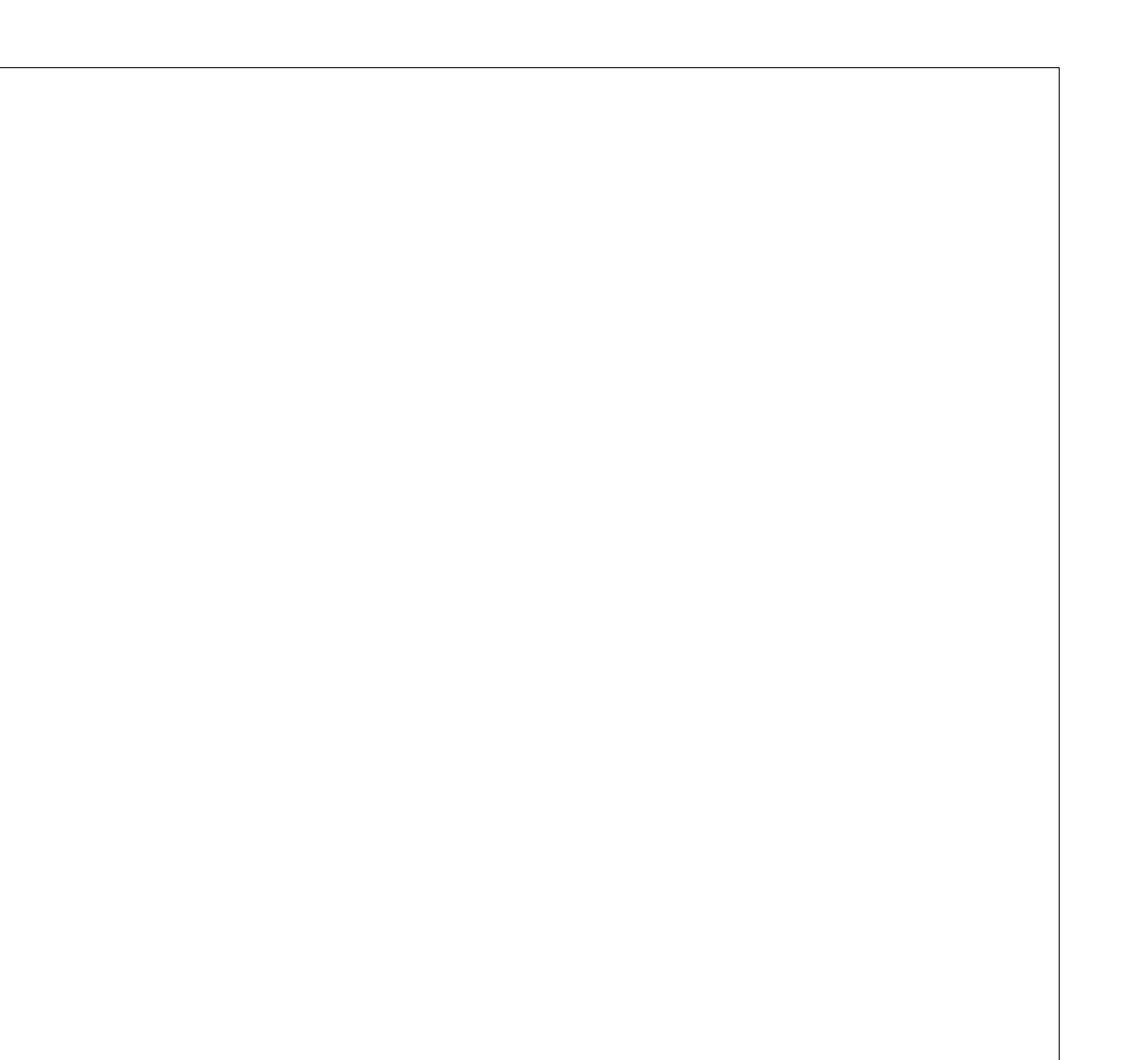

**7 DETAIL**  
3/4" = 1'-0"